

**PROFILO 50X50** PROFILE 50X50

# SPECIFICA DI FORATURA PER STRUTTURA 50X50

## DRILLING SPECIFICATIONS FOR STRUCTURE 50X50

**FORATURA TRAVERSI E MONTANTI**  
DRILLING FOR CROSSBARS AND UPRIGHTS

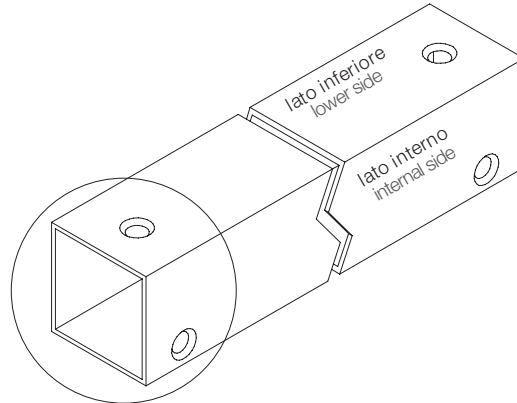
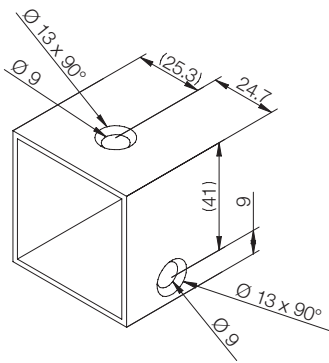

FORATURA PER GIUNTO 7701.0001  
DRILLING FOR JOINT 7701.0001

**ATTENZIONE: le forature sono indicative e possono variare in base alle esigenze costruttive.**  
IMPORTANT: drilling is indicative and may vary depending on construction requirements.

**FORATURA GAMBA**  
DRILLING OF THE LEG

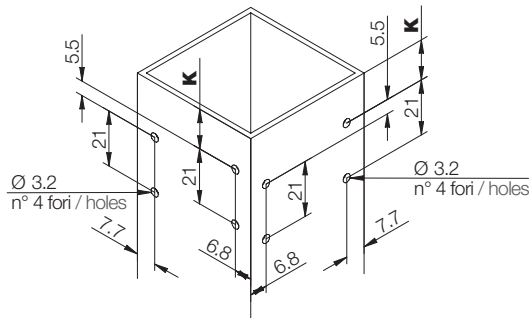

FORATURA PER GIUNTO 7701.0001  
DRILLING FOR JOINT 7701.0001

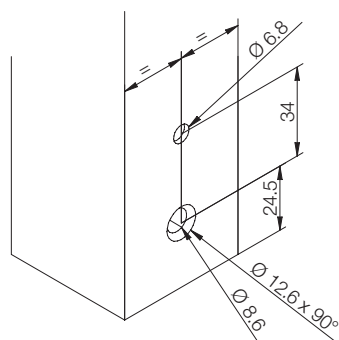
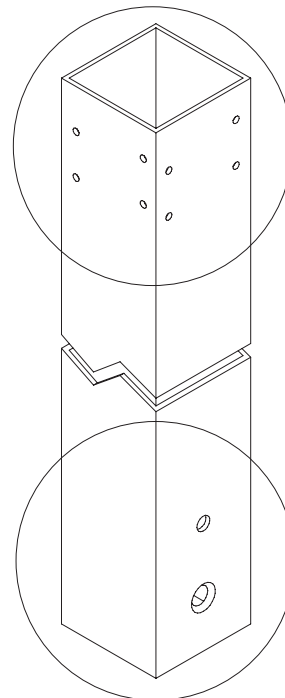

FORATURA PER LIV.001  
DRILLING FOR LIV.001

**K** = 15.2 mm - con tappo superiore / with an end cap at the top  
**K** = 16.2 mm - senza tappo superiore / without an end cap at the top

**ATTENZIONE: le forature sono indicative e possono variare in base alle esigenze costruttive.**  
IMPORTANT: drilling is indicative and may vary depending on construction requirements.